

# Energetics for the Future

Millard S. Firebaugh

# Applications for Energetics Expertise?

- EM Rail Gun Projectiles
- Weaponizing UxV
- Improved Logistics

# Different Physics Provides Increased Capabilities Over Conventional Guns

## PHYSICS

Railgun: Electromagnetic Force drives projectile

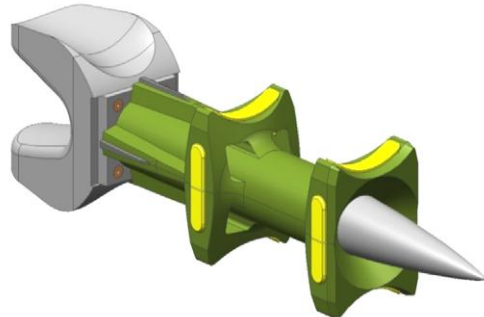
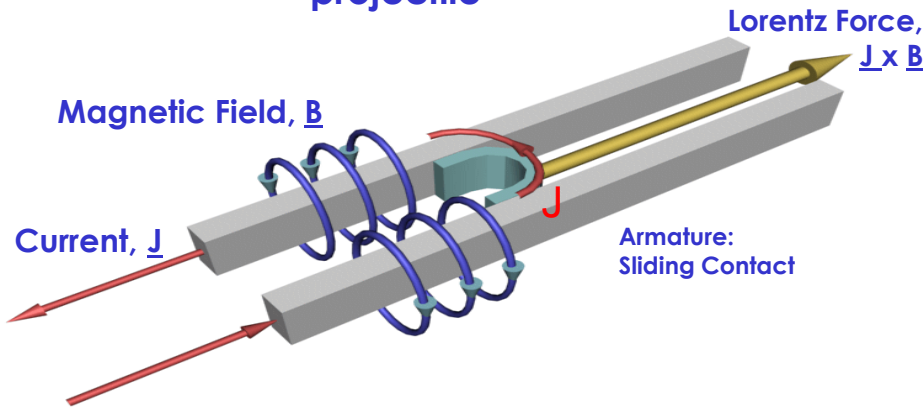

### Launch Package

- Armature
- Sabot with Bore riders
- Projectile

## CAPABILITY

- High muzzle velocity: 2 – 2.5 km/sec (Mach 6-7.5)
  - Long range
    - Extends inner tier of ship defense to horizon
    - Mostly exo-atmospheric flight for indirect fire missions
    - Lifting body projectile further extends range
  - Fast time to target
    - 7 seconds to horizon at sea level
    - 30-40 seconds from sea level to 100,000 feet
  - High Lethality from kinetic energy can be augmented with HE
- Compact projectiles allows for a large number in a ship magazine for sustained high rate of fire



Reaper



Ripsaw







The Protector



# X-47B

“I don’t ever, ever, ever want to hear the term logistics tail again. If our aircraft, missiles, and weapons are the teeth of our military might, then logistics is the muscle, tendons, and sinews that make the teeth bite down and hold on— logistics is the jawbone! Hear that? The JAWBONE!”

LTGEN Leo Marquez, USAF

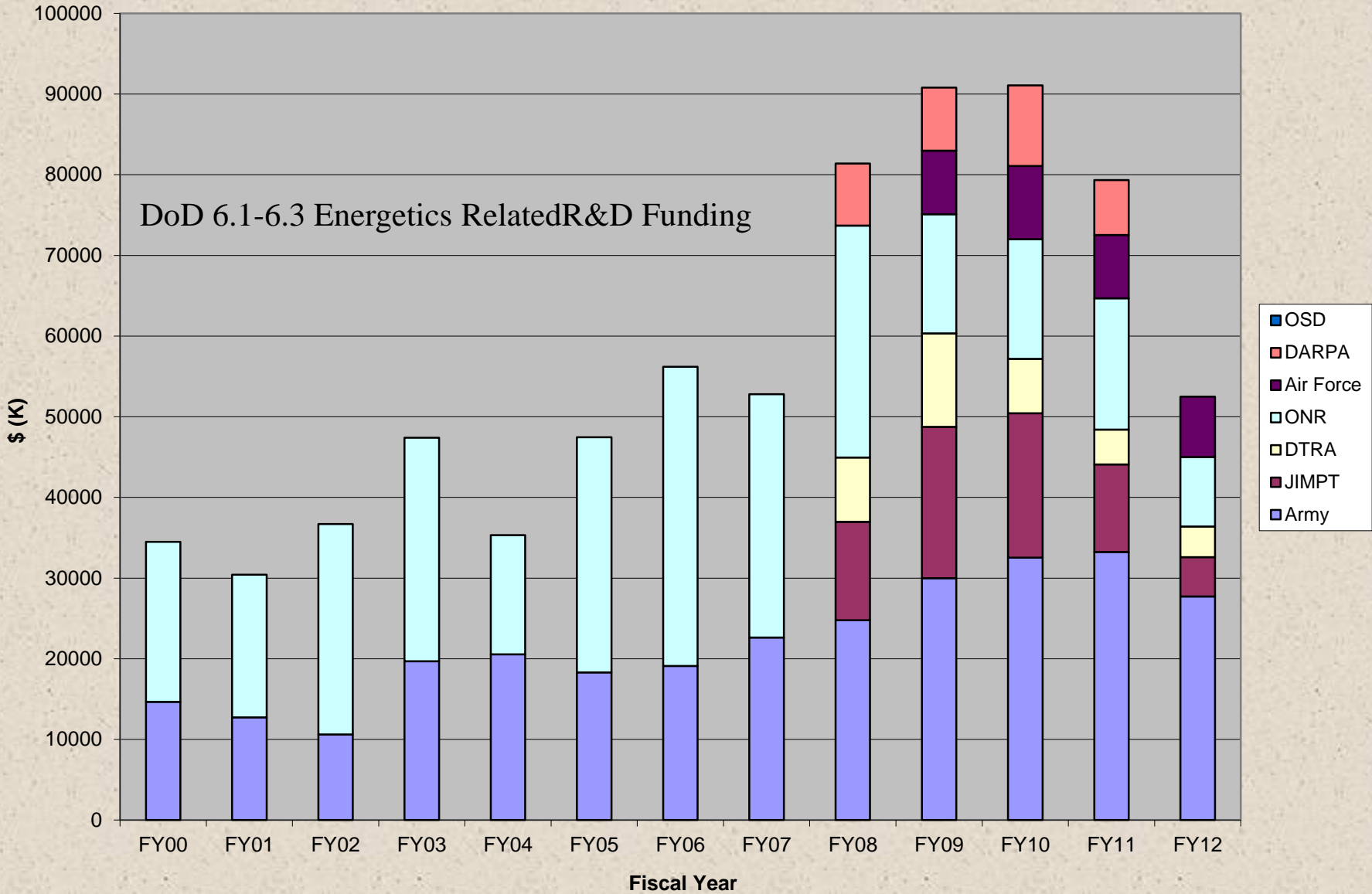



## Revitalizing Energetics Research and Development

- Computational Energetics
- Incremental Improvement is Valuable
- Develop Systems Expertise
- Be Courageous in Looking for the Next Big Thing
- Help the Warfighter

# What's To Do?

- Plan
- Collaborate

“Results Count” CAPT Maylon T. Scott, USN